

HYGIENIC PULSATION DAMPERS AND SURGE ABSORBERS

Designed for CIP applications in the Pharmaceutical, Food, Confectionary,
Personal Care Products, Beverage and Brewing Industries



 **FLOWGUARD**

A Weir Group Company

PROBLEMS CAUSED BY PULSATION

Pulsations are caused by reciprocating positive displacement pumps such as plunger and diaphragm metering pumps, air operated diaphragm pumps, multi-plunger pumps and homogenisers. Rotary positive displacement pumps such as peristaltic and lobe pumps also create a significantly pulsating flow as do filling machines which can, in some applications, be treated as a reciprocating pump.

The most common sign of pulsation is often shaking and noisy pipework - sometimes referred to as water hammer. If left unchecked this can result in partial or complete fracture of the pipe, leaking joints, damaged pipe hangers and wear and tear on pumps and mountings. Pulsations can also cause damage to instrumentation and other system components such as heat exchangers.

The process related effects caused by uneven flow can often be more costly as they can lead to product loss due to damage and waste. Uneven flow to the process can in itself be a problem and causes unstable instrument and sensor readings.

If the process involves spraying, a pulsing flow at the spray nozzle will cause an uneven egress of liquid. This results in uneven coatings which is particularly relevant to some confectionary and pharmaceutical processes such as tablet coating in tumbling machines.

When dosing or metering one liquid into another, slugging can occur with reciprocating pumps since flow only occurs on the forward stroke; on the suction stroke no dosing takes place. The result is a very unevenly proportioned combined flow which can often still be present even after passing through a mixer.

Reciprocating flow on the inlet of positive displacement pumps can cause cavitation and over delivery due to inertia where the suction pipework is long or complex. Cavitation can be recognised by the flow rate being below what is expected (often with excessive pump noise) whilst over delivery is the opposite.

The solution to all of these problems caused by pulsating flow is to install pulsation dampers.

FLOWGUARD HYGIENIC PULSATION DAMPERS

Flowguard pulsation dampers consist of a vessel which contains a volume of inert gas, usually air or nitrogen, at a particular pressure ('pre-charge' pressure). The gas is retained by a flexible membrane within the vessel and process liquid is accessible to the other side. When the pump is on its delivery stroke, part of the flow is displaced into the damper causing a pre-determined rise in pressure to a level dictated by the size of damper selected. On the suction stroke this liquid is released back into the line allowing pressure to fall. Consequently a small amount of liquid enters the damper at the 'peak' of each pulse and is returned to the line when the following 'valley' occurs resulting in the pressure pulsations being absorbed. The slight residual pressure fluctuation is known as the 'level of damping' and is selected to suit the application.

A plain vessel or standpipe could sometimes be used to achieve a similar effect. However, apart from the inherent difficulty of cleaning such a vessel under a CIP regime, the advantage of using a damping vessel with a flexible membrane is that the pre-charge gas is not absorbed by the process liquid and also the gas pressure can be set above atmospheric to keep size to a minimum. The two oscillograph traces shown here illustrate the pulsations caused by a 420 l/hr simplex metering pump both with and without a damper and show just how effective pulsation dampers can be.

PULSATION DAMPER BENEFITS

- Remove pressure and flow fluctuation
- Eliminate noisy shaking pipes
- Provide a continuous steady flow to the process
- Obtain stable instrument readings
- Prevent cavitation due to difficult suction conditions
- Prevent overdosing

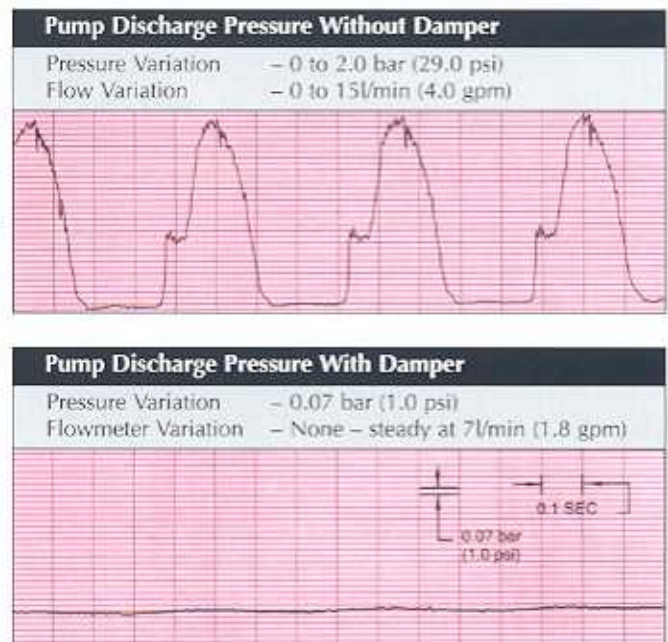



**Certificate of Testing for Cleanability
In-Place in Accordance with the European
Hygienic Equipment Design Group
Test Procedure, 1992**

This is to certify that -

Campbell & Chorleywood Food Research Association have conducted an examination of a
Flowpulsed pulsation damper model: FBTD-10/20/30/40/50/60/70. The damper was supplied with a food class transfer fluid shell and shell
with a polypropylene upper bladder. The results of the test show the damper to be particularly
cleanable and we consider it is suitable for clean-in-place applications.

Signed: *[Signature]* Date: *[Date]*
Signed: *[Signature]* Date: *[Date]*

Campbell & Chorleywood Food Research Association
Clipping Campden, Gloucestershire, UK

FG/TD HYGIENIC DESIGN

Installation: This should be vertically either up or down with care being taken to ensure that air trapping will not occur as this may prevent proper cleaning. For use as a pulsation damper it should be located as close to the pump as possible. For surge applications the unit should be fitted just before the cause of the surge.

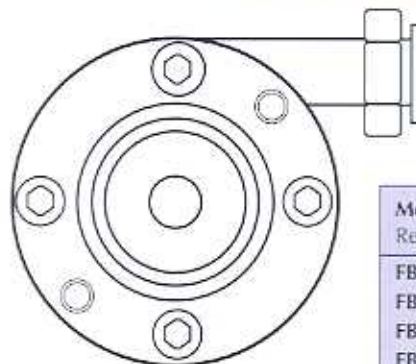
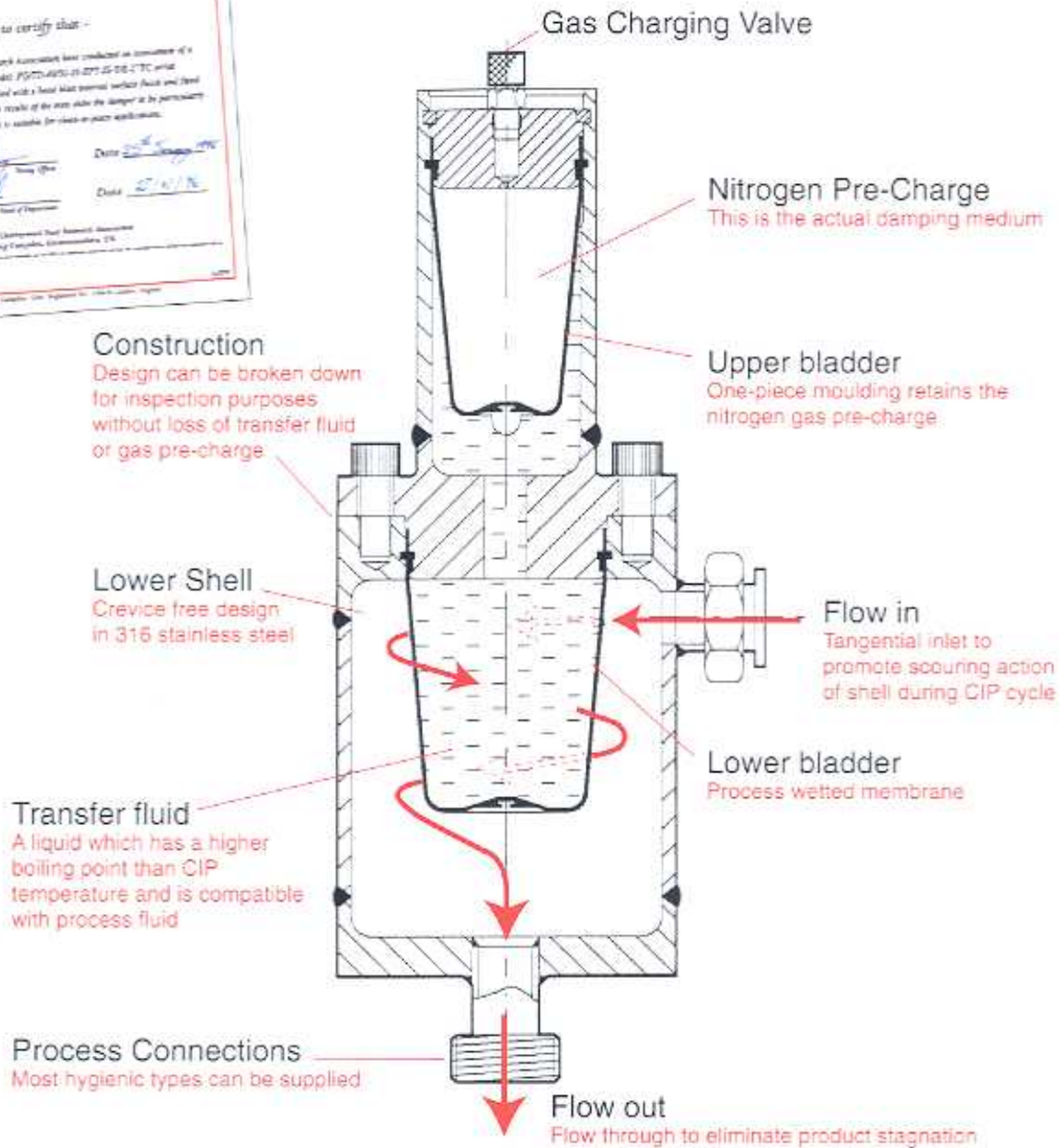

PLAN VIEW

Model Ref.	Volume (litres)	Diameter (mm)	Length (mm)	Weight (Kg)
FBTD-10	0.1	130	280	15
FBTD-20	0.25	140	341	25
FBTD-30	0.5	165	403	35
FBTD-40	1.0	190	428	50
FBTD-50	2.0	228	608	80
FBTD-60	5.0	279	715	150
FBTD-70	10	380	780	250

PROBLEMS ASSOCIATED WITH SURGE

Pressure surges can occur in almost any piping system from a single 1/2" pipe to a complex process layout. They are brought about by a rapid change in the velocity of fluid flow such as might be caused by the closing of a shut off valve or the modulation of a process control valve. The resulting pipe vibration is often referred to as water hammer, shock or surge and it can lead to some surprising and unwelcome effects.

It may be no more than a mild bang or clunk with little or no pipework movement but it can be much more severe resulting in substantial damage. It may be solitary 'bang' or shock, whilst in others it is repeated rapidly producing a hammering effect.

There can be a variety of physical results. Cracked pump casings, valves bodies, stems, seats and heat exchanger plates are not unknown and complete failure of the pipe itself can occur. Heat exchangers are particularly vulnerable. They can suffer from cross contamination due to the plate seals 'pumping' and the seals themselves can be damaged by pressure surges leading to the expensive process of re-sealing. Pressure surges can cause major problems such as damaged instrumentation, leaking joints, relief valves blowing off and blown bursting discs. Apart from the direct costs these incur, with some liquids there may be a cost impact from environmental considerations.



COMMON CAUSES

Valve Operation

In smaller lines this may be triggered by a fast acting valve - often solenoid or air operated - whereas with larger diameter systems the valve may appear to be relatively slow closing but still cause a surge. Problems of this type occur within a wide range of systems from simple elbow taps found in plumbing systems, valves on filling machines to two stage process control valves.

Filling of Empty Lines and Hoses

These problems occur where flow generated by either a pump or a tank/reservoir fills an empty or partially empty line and meets a restriction or change of direction. Although generally encountered after a shutdown some processes experience this problem on a regular basis.

AVOIDING AND CURING SURGE

Many surge problems can be avoided by good pipework design and exercising care in the selection and installation of process valves. Slowing down the speeds of valve operation can have a significant impact.

If it is not possible to avoid the propagation of a surge then the pipeline can be protected by fitting a surge suppression device or surge alleviator.

FLOWGUARD HYGIENIC SURGE ABSORBERS

The basic surge absorber comprises a pressure vessel in which is fitted a flexible membrane. One side of this is filled with an inert gas such as air or nitrogen to a pre-determined pressure (the pre-charge pressure). The other side of the membrane is connected to the process fluid. As the surge reaches the absorber its higher pressure causes liquid to be displaced into the unit compressing the gas pre-charge which typically would have been set just below the normal operating pressure of the system.

The sizing of the surge absorber would allow the rise in pressure due to liquid being taken into the unit to be limited to a pre-determined value suitable for the design conditions of the plant. Location of the unit is important and it would normally be fitted just upstream of the cause of the surge to prevent the pressure wave travelling back up the line and damaging upstream equipment.

Although single membrane surge absorbers are suitable for most non-hygienic duties, where there is a CIP requirement a double membrane design (the FG/TD type) should be used; the principle of operation is however, the same.

HYGIENIC ASPECTS OF THE DESIGN

The FG/TD design was designed with the food, beverage and pharmaceutical industries in mind. It is a double membrane or transfer damper and is suitable for clean-in-place applications. In tests carried out by Campden & Chorleywood Food Research Association to the EHEDG protocol it was found to clean better than the reference pipe.

The use of two membranes which are hydraulically connected with a transfer fluid overcomes the problems of crevices and product stagnation which are inherent in most other damper designs. To ensure efficient cleaning during the CIP cycle it is a true flow through design with the product wetted lower shell being crevice free and having no small corners or dead areas. It is normally manufactured in 316 stainless steel with a choice of food quality materials for the lower (process contact) membrane. The side inlet port is attached tangentially to promote a scouring action of the shell during cleaning and the unit can be partially dismantled for inspection of the lower shell and membrane - the process wetted parts - without loss of precharge pressure or transfer fluid.

DESIGN SELECTION

Transfer Fluid

The transfer fluid is selected in conjunction with the client. It needs to be compatible with the process fluid (in case the lower membrane fails) as well as the upper and lower membranes. There also needs to be a substantial margin between its boiling point and the maximum operating or cleaning temperature reached by the system. Commonly used liquids are sterile water, vegetable oils, alcohol and glycerine. In cases where a membrane failure detector is required it is also an additional requirement to have a (significant) difference in conductivity between the process and transfer fluids.

Membrane Material

Many different rubber compounds are available dependant upon the process fluid and cleaning regime. The upper membrane is usually a standard rubber grade as it is only in contact with the transfer fluid. The lower (process wetted) membrane can be provided in black or white, in either a standard or food quality compound. Certificates for both the housing and membrane materials are available on request.

Connections

Process connection size is normally the same as the line diameter to avoid constriction of flow and maintain velocity. The connection type is specified to suit the customers requirements; any type can be provided such as RJT, IDF, ILC, SMS, DIN 11851, Tri-clamp etc.



DESIGN OPTIONS

Hot Water/Cold Water Jackets

These are normally manufactured around the lower shell as this is the part which holds process liquid; jacket connections can be screwed or flanged.

Surface Finish

If something other than a standard finish is required, that of the internal (process wetted) parts can be specified separately to that of the external parts. Mechanical polishing is widely used and, although customers particular requirements can be met, most finishes fall into the following three ranges: 0.4 to 0.2 Ra, 0.1 to 0.05 Ra and 0.025 to 0.0125 Ra, which roughly correspond to 'satin', 'dull mirror' and 'mirror'. Electro-polishing and bead blasting are also used.

Failure Detection Device

A conductivity probe and controller can be fitted in order to detect a rupture of the lower (process contact) membrane. The probe is located in the transfer fluid which is selected to have a different conductivity to that of the process fluid. Should the lower membrane fail then the transfer and process fluid will mix. The resultant change in fluid conductivity sensed by the conductivity probe can either set off an LED or be linked to an alarm.

The FG/TD hygienic damper solves problems!

Product contamination - Pharmaceutical Manufacture Contamination of coolant into product at a major Insulin Plant was the result of pulsing flow passing through plate type heat exchangers fitted to the suction side of triplex pumps. Steady flow to and through the heat exchanger was achieved by fitting an FG/TD hygienic pulsation damper prior to the pump – after the heat exchanger – on each of the twelve lines involved.

Production shortfall during blending - Cola Production A shortfall in production was traced to a reciprocating blending pump which was not delivering the predicted flowrate. The cause was found to be cavitation occurring in the pump due to very long suction pipework, a problem which was cost effectively resolved by fitting an FG/TD damper to the pump inlet.

Accurate brine and vegetable oil blending - Margarine Manufacture A new production line used a multi-headed metering pump for proportioning prior to blending. Accurate and even blending was imperative and FG/TD pulsation dampers were fitted to prevent slugging and get uniform flow into the mixer. They also enabled the flowmeters to give consistent readings.

Heat exchanger damage - Brewery Leaking seals and cracked plates on a heat exchanger used for wort cooling were found to be due to pressure surges caused by a control valve downstream of the cooler. An economic solution was to fit a hygienic surge absorber just upstream of the valve keeping the pressure peak to acceptable levels.

UV Steriliser damage - Ice Cream Plant - Breakage of glass tubes and clamps on a sugar solution UV steriliser was found by a well known manufacturer to be due to pressure surges caused by pneumatic valves closing. The costs of downtime and cleaning up more than paid for the FG/TD unit which cured the problem completely.

Uneven 'tablet' spray coating - Confectionary Manufacturer

A problem of uneven starch/sugar coating on a well know confection was found to be caused by pump pulsations affecting the spray pattern in a tumbling type coating machine. The fitting of a hygienic pulsation damper cured the problem and eliminated all lost product due to coating thickness variation.

Homogeniser problems on box filling - Dairy Plant Repeated problems with a homogeniser in a large dairy were found to be due to surges caused by fast acting valves on a box filling line. Fitting a hygienic surge absorber cured the problem and also improved the filling accuracy.

High cake decoration wastage - Bakery An uneven width of chocolate decoration on cakes was being caused by the pulsations from the feed pump. A CIP damper fitted to the outlet of this pump brought the width variation down to barely detectable levels, eliminating this cause of waste product and improving product consistency.

Mould filling shortfall - Confectionary Manufacturer Chocolate moulds at a well known company were not filling completely when the line was run at maximum speed; the filling machine could not draw liquid in fast enough. The solution was an FG/TD hygienic unit fitted just before the filling machine which acted as a store for chocolate and allowed the head to fill completely.

Homogeniser pulsations - Ice Cream Manufacture A Midlands manufacturer had problems of pipe vibration and noise on both the upstream and downstream sides of a homogeniser. Its reciprocating action was clearly the root cause and the fitting of dampers to both the inlet and outlet proved to be the appropriate remedy.



Flowguard USA

Tel: (800) 566 7857

Fax: (713) 673 5113

e-m: flowguard@flowguardusa.com

Flowguard UK

Tel: +44 (01663) 745976

Fax: +44 (01663) 742788

e-m: flowguard@flowguard.com

Flowguard Germany

Tel: (0211) 23 60 40

Fax: (0211) 23 10 19

e-m: flowguard.gmbh@t-online.de